



Cobalt PSU-2+

The Concept:

Make PSU-2+ the best way to power Cobalt motors and DCC systems, but keep the price at a level that represents great value. Use only quality components and a custom created "Toroidal transformer" for perfect stability under load. Add tight regulation and overload protection. Keep it easy to use & wire.

PSU 2+ is a totally self-contained, mains powered and super-stable dual output power supply that can power more than 200 Cobalt point motors at 9 volts DC AND it can also be bridged to give a stable 5 amp DCC power supply.

A good power supply needs to be substantial - PSU-2+ is only 93mm wide x 149mm long (165 overall) x 71mm high, but it is packed with robust, heavy duty parts so it weighs nearly 2kg! PSU-2+ also includes a totally silent cooling fan and very high quality voltage regulation for absolute stability so it will take any high current load in its stride.

PSU-2+ is quite unusual in that it offers a 3-terminal (+) (+/-) and (-) regulated DC output. This makes it very, very simple to connect and because it can provide a reversible voltage using only a single pole double throw switch (vs the double pole switch needed with conventional power supplies) it also cuts wire use and wiring effort by quite a considerable amount, making your task easier and greatly simplifying wiring of Cobalt point motors as well.

PSU-2+ will give perfect control for up to 200 Cobalt point motors and can provide the best possible stability and power delivery for all brands of DCC system.

Cobalt PSU-2+ Overview

Connection just couldn't be easier. PSU-2+ is fully compatible with and standards approved for mains power use in the UK, Europe, Australia, NZ and other countries using standard domestic 220~250v AC mains power.

We chose an international standard "Figure 8" type mains power lead so modellers in any country can also be supplied with the correct mains connection without the need for changing plugs.

Cobalt PSU-2+ Connections

Output connection wiring is clearly indicated by the diagram above the three-terminal connector.

A and B are two separate output channels, and each individual channel is able to supply a very stable 9v DC which remains the same with any supply voltage between 200 and 270 volts.

You can also bridge the two outputs by connecting directly between terminals A and C to deliver an equally stable 18 volts DC @ 5 amps to make it a perfect DCC system power supply. PSU-2+ is 100% compatible with ALL quality DCC systems.

PSU-2+ CONNECTIONS

Power on Indicator
Output Connections
(An easy to use pluggable type screw connector)

Mains Fuse

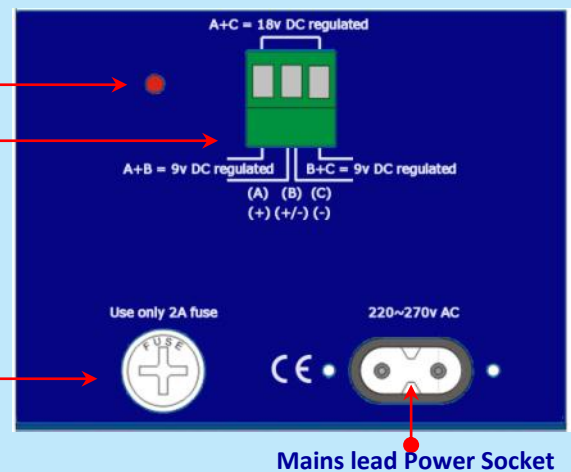

PSU-2+ simplified wiring for Cobalt (& other DC motor drive point motors)

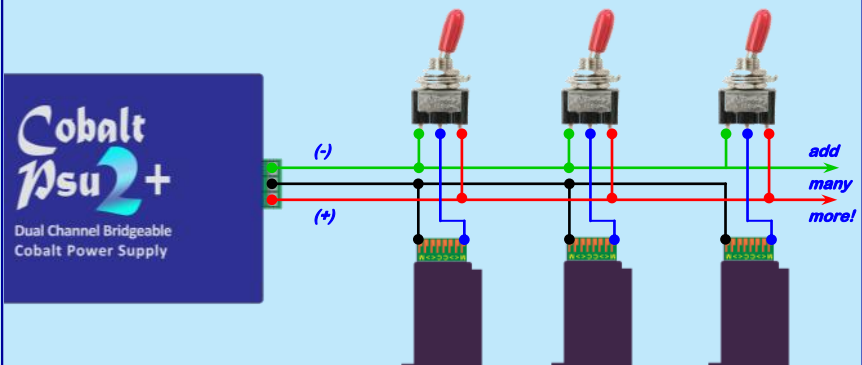



Cobalt PSU-2+

Cobalt PSU-2+ is very easy to use as a DCC system power supply - This shows how

Cobalt PSU-2+

Dual Channel Bridgeable
Cobalt Power Supply



Any good quality

DCC SYSTEM

Which requires
4~5 amps

Cobalt PSU-2+ with Cobalt Classic and Cobalt-S Levers...

All done with very few wires leaving you **FOUR** free switches for signals, lamps on a mimic panel and any form of interlocking or conditional control that you might need!

Cobalt PSU-2+

Dual Channel Bridgeable
Cobalt Power Supply

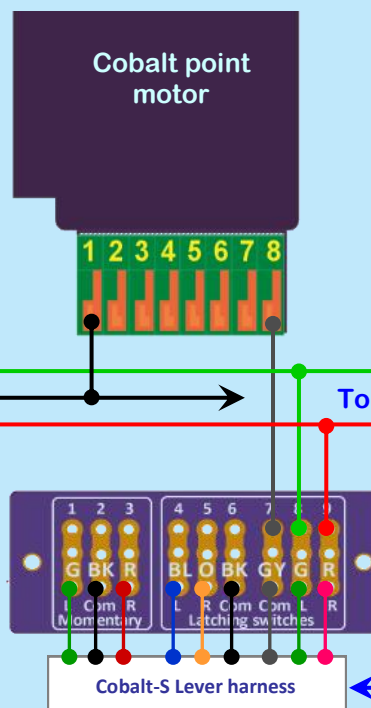

This example was created using Cobalt point motors, however connections are similar for all brands of DC point motors. Please follow the instructions that were supplied with your chosen solenoid brand for the exact position of connections.



Cobalt Psu 2+

Using PSU-2+ greatly simplifies the wiring of your layout.

Here's a simple example that shows how combining PSU-2+ & Cobalt can help you to achieve everything you have ever wanted with far less wiring complexity.

Cobalt Psu-2+ with Cobalt Classic and Cobalt-S: Using PSU-2+ allows you to use just 1 x 3-wire SPDT switch on Cobalt-S to work a full crossover and also switch your control panel lights. This then leaves 2 switches free on the Cobalt-S lever. The frog polarities are controlled by 1 switch on each Cobalt leaving 2 more free for interlocking and signals etc...

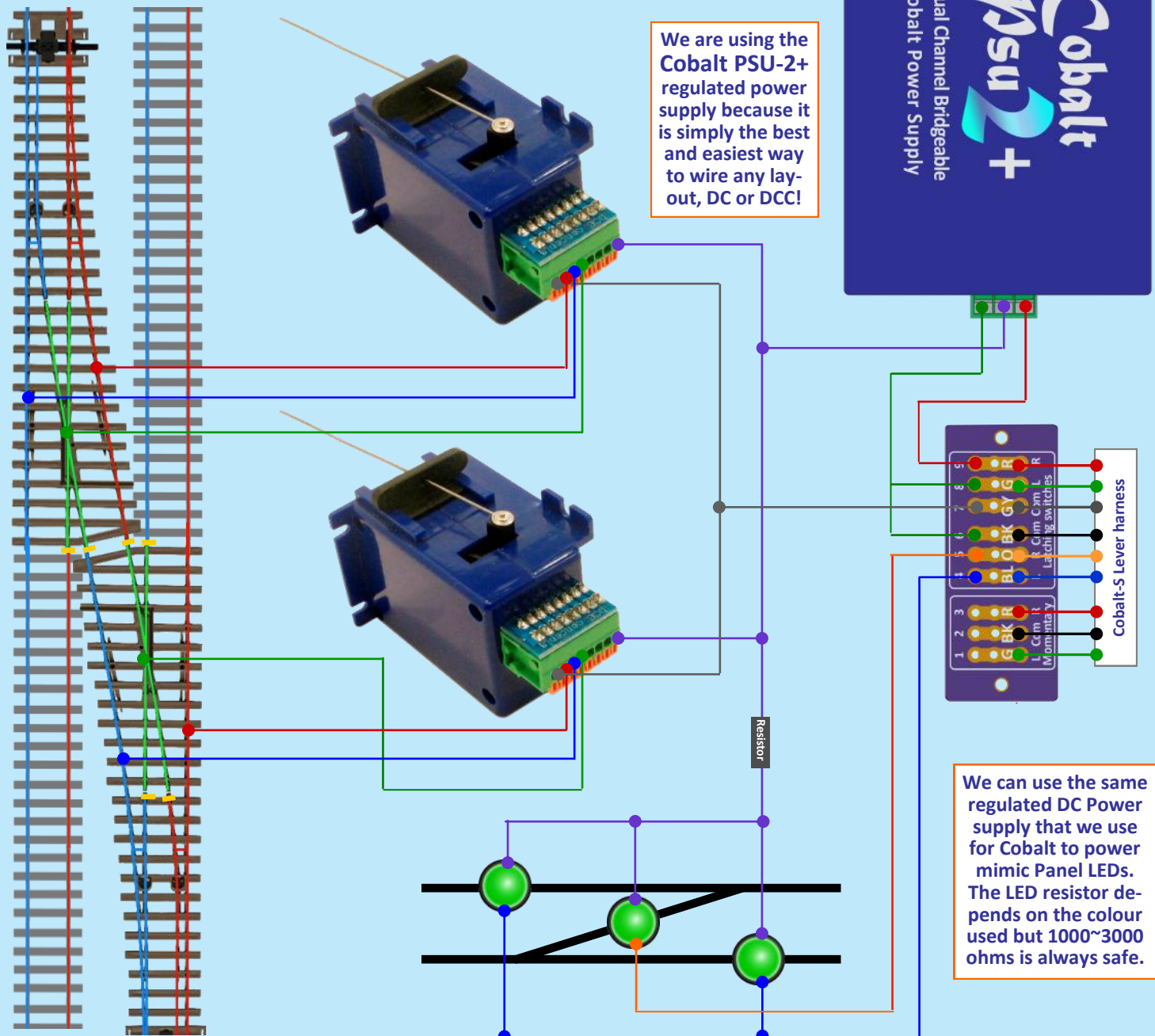

This example was created using Cobalt point motors, however connections are similar for all brands of DC point motors. Additionally, while we have shown the use of Our Cobalt-S Levers, you can of course also use other SPDT switches or on-on levers like the Peco model PL23



Cobalt PSU-2+

Using PSU-2+ greatly simplifies the wiring of your layout.

Here's a more complex example that shows how combining PSU-2+ & Cobalt will let you easily achieve things like interlocking of the relationship between point motors & turnouts. (In this new example we use a Peco 3-way)

Simple Interlocking with PSU-2+ and Two Cobalt motors.

Controlling two Cobalt point motors with PSU-2+ needs very few wires and only takes up ONE switch on each Cobalt-S lever - of course if you don't have Cobalt-S the same switching approach can also be done with a simple SPDT on-on switch.

Look at the **RED** wire. We've routed the common (+/-) wire as a simple electrical "interlocking" between the two Cobalt motors. This was done very simply by routing a power wire to Cobalt #1 via a switch on Cobalt #2, so that #1 can only be activated if #2 is set to the correct position (ie: switched to allow access to route A and B).

Adding LEDs. LEDs are simply placed in-line in the wire that runs from the switch to Cobalt. As this wire reverses its polarity, one LED will light per direction.

Powering Frogs. Rather than complicate the drawing, we can explain Frog wiring quite simply. **Frog 1 and 2** are always the same polarity and are switched by the 2nd switch on Cobalt Motor #2. (frog wire to terminal 5, Blue rail to T 7, Red rail to Terminal 6). **Frog 3** is switched by Cobalt motor #1 (Frog to Terminal 5, Blue to T6, Red to Terminal 7)

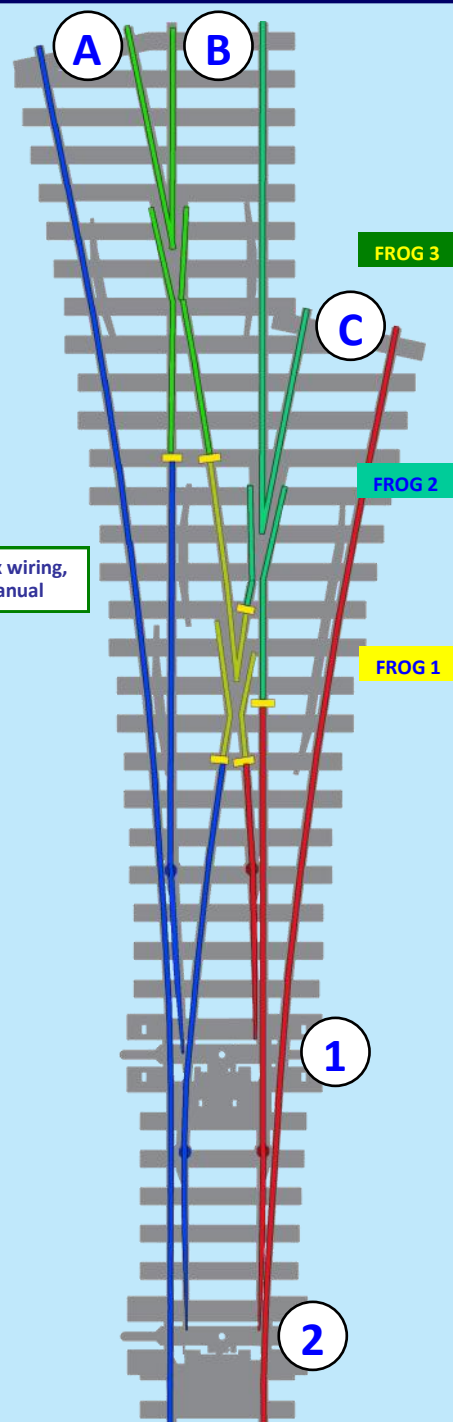

You can find other examples of interlocking & complex wiring, including slips and scissors crossings, in the Cobalt-S manual

Cobalt PSU-2+

Dual Channel Bridgeable Cobalt Power Supply

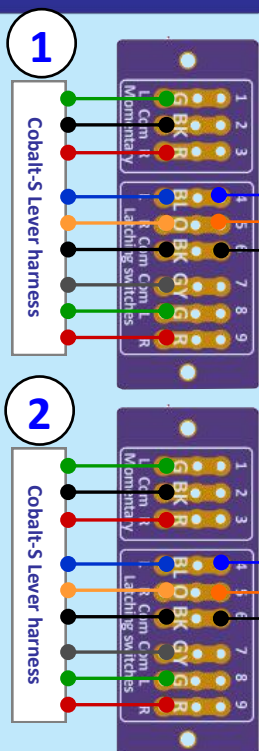

COBALT "Classic" Point Motor 1

COBALT "Classic" Point Motor 2

Motor control, LED's and "Interlocking" take up only three switches. If you use a standard SPDT switch you will still have 3 spare on Cobalt #1 for other things... but if you use Cobalt-S Levers, you will have a total of 7 free switches available to use on frogs, signals, safety or isolating sections & the like (5 are SPDT on-on, & 2 are SPDT pole momentary switches)

We have introduced TWO special things on this page: Wiring the Cobalt-S switch as a SPDT changeover switch and making the power of one Cobalt conditional on the position of the other. LEDs etc are easily wired using the spare switches on Cobalt motors or the Cobalt-S Switch.



Cobalt PSU-2+

PSU-2+ Warranty and Service

PSU-2+ meets all required standards for sale in the United Kingdom, Australia, Europe and New Zealand. PSU-2+ is made using high quality parts and is guaranteed for 12 months from the date of purchase. Should you experience any problems please disconnect PSU-2+ from the mains power and first check the condition of both the power lead and the mains fuse.

This product is not user serviceable, so if fuse or lead replacement do not remedy the problem, or your PSU-2+ has suffered physical damage in any other way please contact us or our distributors.

Under no circumstances should unqualified persons attempt service of this mains-powered device.

Spare parts and any required servicing are available via DCCconcepts or from our United Kingdom distributors Gaugemaster Controls Ltd who are also equipped to carry out any required servicing.

Notes:

Do you need more assistance or guidance?

We are always happy to assist modellers in any way we can to help them get the best from any of our products, so if you need advice, help or further information at any time, please feel free to contact us at questions@dccconcepts.com (due to time zone changes please allow up to 48hrs for our response)