

Wiring Point-work & Special track conditions for DC or DCC

Wiring the track... In plain English, with diagrams!

If we had a \$ or £ or € for every time we've been asked how to wire track and point-work, we'd be writing this on a beach somewhere while sipping a cold beer! A great layout needs good trackwork, so first - a word about trackwork and getting good performance. Choose carefully!

DO think about making your own turnouts if you have even moderate skills. It is not as hard as you think, needs only basic skills and tools... and we do our best to make it easy with our top quality gauges, trackwork frets and templates. PLUS we will soon provide a detailed "How to make track" tutorial too. Interested? Then call or email us and we will do our best to help you.

No matter what scale you will model in, DO NOT even consider using insulated frogs! Yes, lazy retailers who do not understand what they sell - and modellers who have never done a proper job of laying track so it runs well may well recommend it to you... but do NOT be tempted.

No matter which brand makes the turnouts, if you use insulated frogs, you WILL have small locos stalling or also suffer from wider wheels bridging the frog tip and creating momentary shorts that are hard to fix and really are a source of constant frustration.

Use more realistic rail sizes please: Usually this will be code 55 in N, or Code 75 and 83 in OO or HO Scale. Unless most of your stock is old Lima or older European prototype with deep flanges on the wheels that could cut pizza's, please do NOT use code 100 track. It looks over-scale and your whole layout will never look as good as it could with code 75 or code 83 rail. (by the way the "code" isn't very clever or special - it is just the height of the rail in thousandths of an inch)

There is a practical reason for using smaller rail sizes too... EASIER laying - smaller rail profiles look better but they are also MUCH easier to work with because they bend more naturally and more easily and that makes it easier for you to lay track-work that flows well from straight to curve etc... The range of turnouts is nicer too. Leave the code 100 for fiddle-yard or train-set use!

Speaking of point-work and turnouts: Stick with Medium-to-large radii for all point-work... this is because small radius turnouts always have problems with larger locos and longer rolling stock, You WILL get poor running and derailments if you use them. They look toy-like too of course!

We will cover only the wiring of live-frog turnouts here, because that is how it should be done for best performance. DC or DCC. It's easy to do and you'll be glad you did it right when it runs well!

Stick with ONE track standard if you can. We'll talk only "ready to run" HO/OO here and It may change (actually it WILL, soon) but right now, Peco Electro-frog code 75 is the most usable for UK prototype modelling and not bad for US modellers too, the Tillig Elite code 83 range is excellent for those who model European & Peco code 83 would be my first choice for US modellers.

SO - Lots to think about. Meanwhile, on to wiring point-work & special wiring conditions.

Wiring Point-work & Special track conditions for DC or DCC

#1. The basics of wiring a turnout correctly.

We also cover this subject in detail in another advice chapter "Advice #2—Making Peco better".

That bulletin also includes how to improve the look of a Peco point, so the more adventurous among you might like to check it out! Basically what we need to do is easy, as most of the prep work is now done for you by Peco.

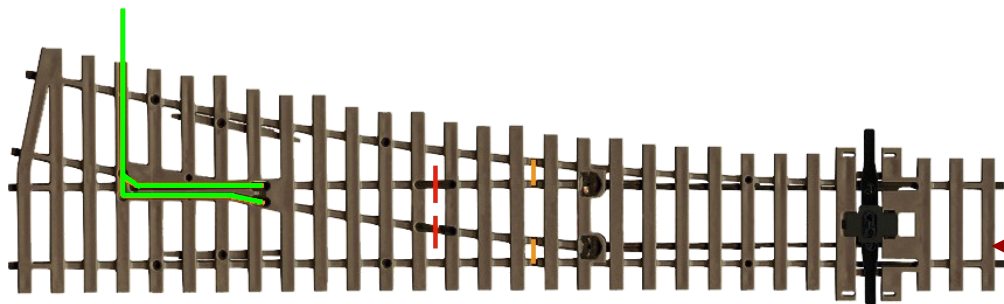

Step 1 - improve the power flow

(1) turn it over. You should see a wire attached to the frog area. Pull it from its slot ready to attach a Green dropper (it'll be connected to the common wire of one of Cobalt's switches)

(2) There are two orange bars on the drawing to the left. These are wire links you should add (solder them between stock and closure rails).

(3) There are two red lines. Older turnouts will need the rails cut here. Newer turnouts already have the rails gapped., but there will be wire links here... Please remove or cut them.

That's it - just wires to attach now!

Step 2 - attach the droppers

(1) attach the green wire to the frog. Connect it to the common terminal of one of Cobalt's built-in high-power SPDT switches.

(2) Attach the other 2 wires (the red and black) for the track power to the blue and red rails. These wires go to the other two terminals on the same Cobalt switch.

Now, when you change the turnout, the polarity of the frog will change to match the route and you will have perfect running!

These quick & simple improvements will give better overall reliability with both DC and DCC powered layouts.

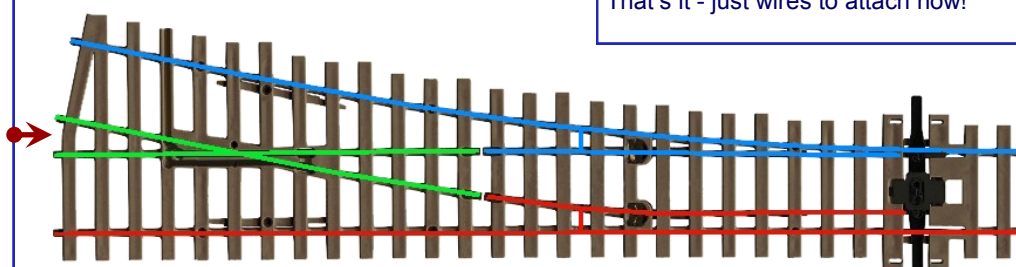

That's it - This is the first step in preparing ANY point-work for use, & now you are ready to go. Easy wasn't it.

This same principal applies equally to ALL Peco point-work in OO and HO. Other brands may be structured a bit differently but the same principal applies - Isolate the frog so it can be switched with the turnout, and remove ALL reliance on physical blade contact by binding all closure rails and blades on the same side of the turnout together.

By the way - N scale Peco is designed slightly differently and I'm assured by modellers in N that the gaps & links aren't needed due to these differences, so if you are in N, you may skip the "gapping/bonding" part. It's up to you.

#2. The basics of using insulated joiners or isolating gaps.

Follow this simple principal. Frogs need to be live, so they always need to be isolated. This is easy to do - and you will find that even for a novice, its easy to work out where it needs to be done.

To make this (&the rest of the text of this document) simpler, we will use some of the terms that commonly understood in relation to point-work or turnouts. So... here is our 1,2,3 of terminology to make it easier.

- (1) Point, switch, turnout, whatever: We will call it all "pointwork" and "Turnouts" from now on.
- (2) Look at the turnout images above. The green part is actually called the common crossing, but the pointy bit where the two rails converge at the LHS is more commonly called the "Frog" by modellers, so Frog it is!
- (3) Look at the turnout images above. Think of a shoe. The LHS is called the HEEL. The RHS is called the toe.

Now - on to the next steps. We'll move on to adding point-work in combinations and on a layout!

Wiring Point-work & Special track conditions for DC or DCC

WIRING AND SWITCHING FROGS - Lets get the basics sorted out first. For this, we will use the basic crossover to give you a guide for polarity & frog isolation that works in all circumstances.

Once we have prepared the point-work, the hard work is done and wiring is easy. Here is a very simple rule to follow. "When any two points face each other, the frog rails need to be isolated"

These examples show this perfectly. It is just two points in a crossover, but it shows why and where frog isolation needs to exist. Use these examples as your guide and you'll be able to do anything you need!

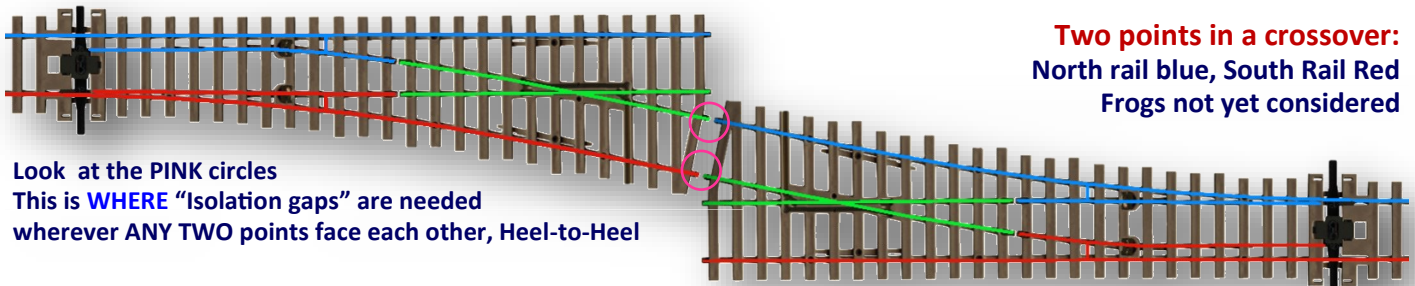

Look at the PINK circles
This is **WHERE** "Isolation gaps" are needed
wherever ANY TWO points face each other, Heel-to-Heel

Two points in a crossover:
North rail blue, South Rail Red
Frogs not yet considered

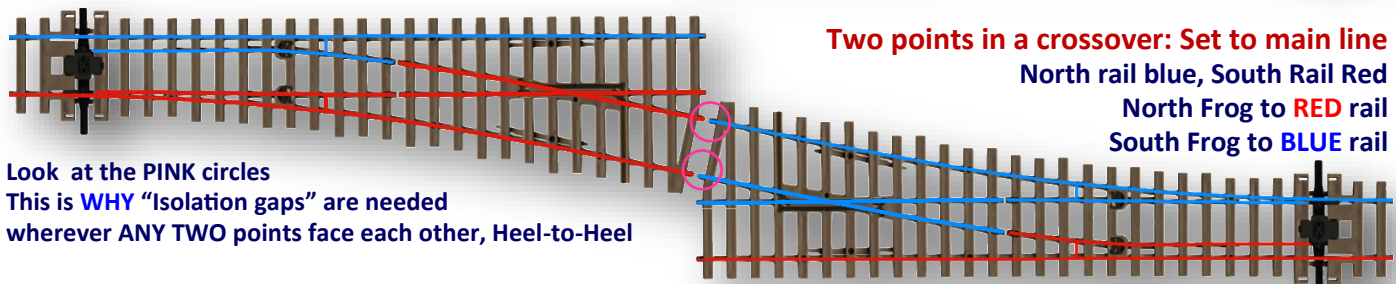

Look at the PINK circles
This is **WHY** "Isolation gaps" are needed
wherever ANY TWO points face each other, Heel-to-Heel

Two points in a crossover: Set to main line
North rail blue, South Rail Red
North Frog to **RED** rail
South Frog to **BLUE** rail

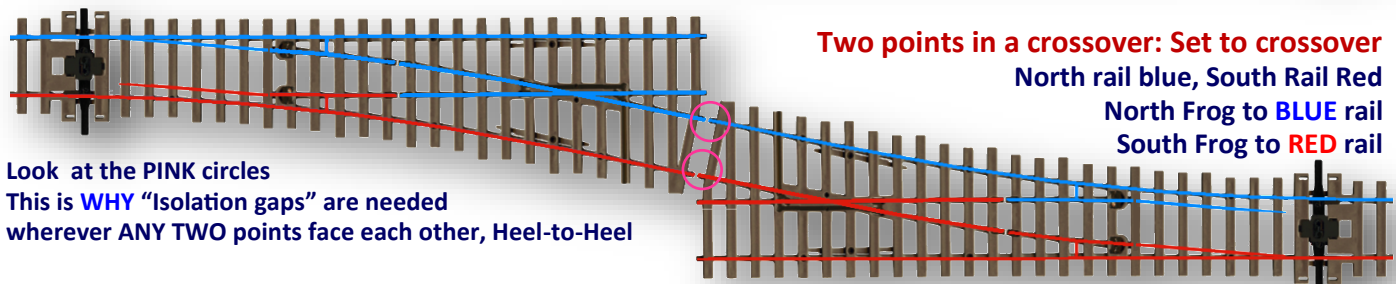

Look at the PINK circles
This is **WHY** "Isolation gaps" are needed
wherever ANY TWO points face each other, Heel-to-Heel

Two points in a crossover: Set to crossover
North rail blue, South Rail Red
North Frog to **BLUE** rail
South Frog to **RED** rail

Switching the frog is easy with DCCconcepts products. (The Frog wire is shown in green)

Using Cobalt Ω or iP Analog

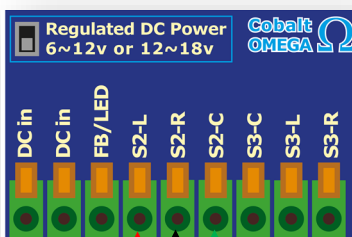

Frog = Green

Using Cobalt iP Digital

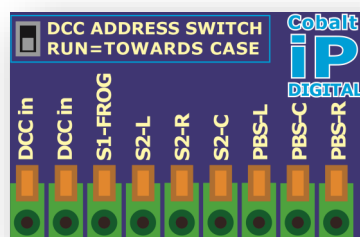

Frog = Green

Using AD-S2 or AD-S8fx

(For all Solenoid brands)

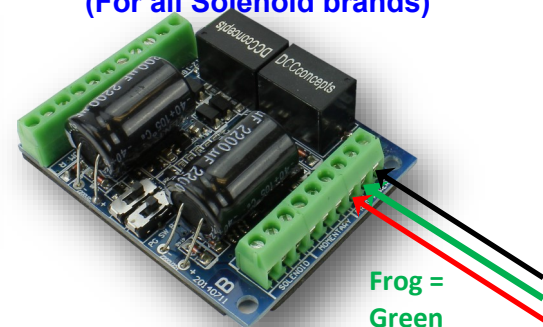

Frog = Green

The "Left & Right" wires may need swapping as this depends on the actual point-work orientation

Wiring Point-work & Special track conditions for DC or DCC

A reminder - ALL examples and the things we use for switching such as Cobalt motors, Cobalt-S levers and AD or AD-S accessory decoders will work as well on DC as they do on DCC, so you can use these diagrams for ANY layout, with ANY form of control.

We are of course aware not all of you will use DCCconcepts products and that is fine: If you choose to use other brands, just translate what we show you to match the connections on items that you choose.

OK: Now we have all the basics under our belt, on to commonly asked questions:

"how do I wire a crossover"?

We'll assume solenoid motors & use our AD-S2fx here, as it has a built-in CDU for each output as well as built-in frog switching and LED outputs for your control panel. This makes it efficient and economical!

NOTE: Wiring colours are there just to make it clear which wire goes where - Choose your own wiring standards!

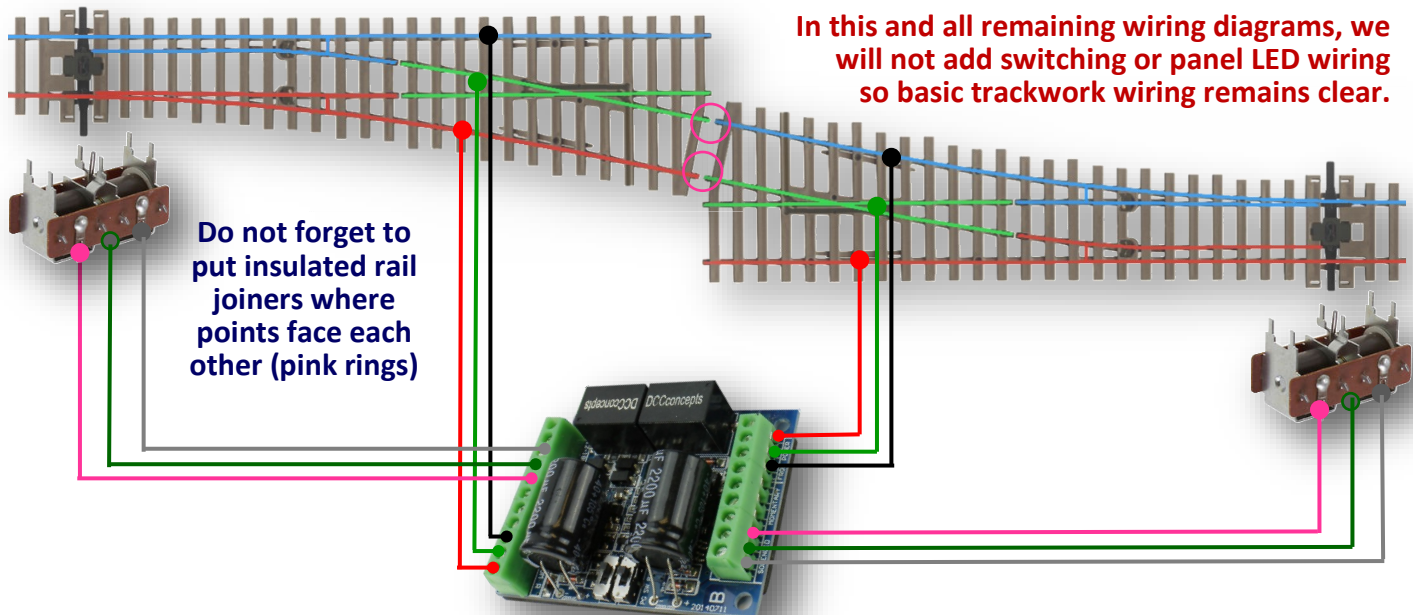

NOTE: Wiring colours in our drawings are there to make it clear which wire goes where.

To make sure your layout wiring is consistent & you can troubleshoot later, choose & stick to standardised colours!

Adding LEDs for the control panel - Cobalt Ω Omega and IP and Cobalt AD-S Solenoid Decoder

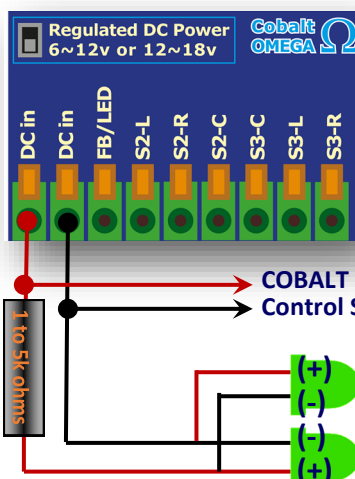

Adding LEDs for the panel

We show our preferred method for Cobalt Omega Ω and iP on the left.

This means that the LED is not in series with the motor leads and so does not vary drive power or dim when the Cobalt motor is moving.

With AD-S2fx or AD-S8fx Solenoid decoders, we've added pre-loaded LED outputs under the PCB making it really easy to add indicator LEDs.

Just go ahead and add the LEDs. You do not need to add a resistor!

TIP

You can also use the AD-S2/8fx LED connection points directly as computer IO or feedback

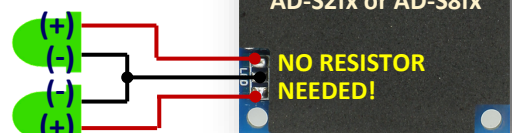

Wiring Point-work & Special track conditions for DC or DCC

Adding Safety interlocking: #1 - Stopping the train

We've all done it. Relaxed for a moment and before we know it, the train has derailed. We are going to show you TWO ways of preventing this problem. They will work on either DC or DCC powered layouts!

- On this page - "Stopping the train". how to use the integrated switching of Cobalt point motors (or the DCCconcepts DCP-REX "relay extension boards" (They will be released soon) to stop trains crossing point-work that has been set against them, causing derailments & short-circuits.

On the next page - we will show an easy way to fully automate a point-work change by adding a detector linked in parallel to the switch connections of a Cobalt iP Digital, Cobalt AD-2fx / AD-8fx decoder OR an AD-S2fx / AD-S8fx Solenoid decoder.

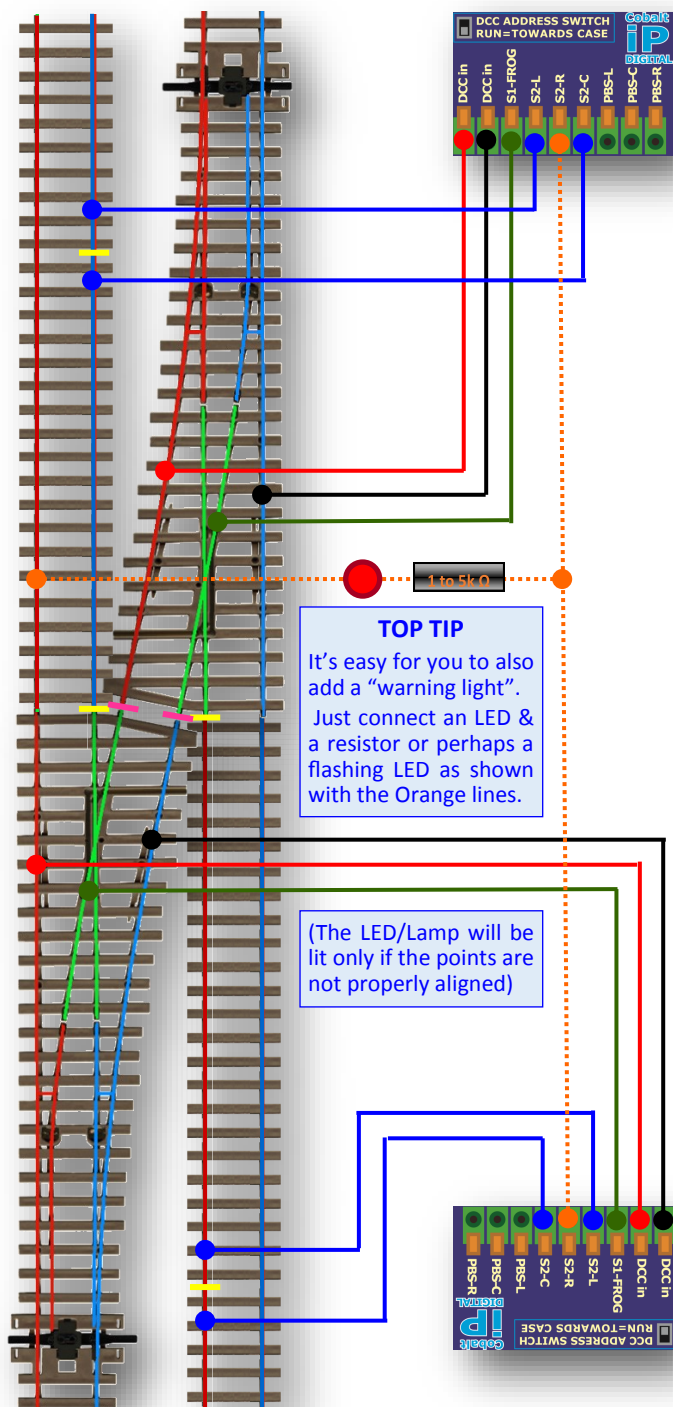

TOP TIP
It's easy for you to also add a "warning light". Just connect an LED & a resistor or perhaps a flashing LED as shown with the Orange lines.

(The LED/Lamp will be lit only if the points are not properly aligned)

We've used a crossover here, however the wiring structure is of course the same as it needs to be for any correctly wired live (electro-frog) point-work.

The PINK bars on the drawings are the isolating joints that separate the frogs.

The YELLOW bars are there to isolate a section of the main line rail just ahead of the heel of each turnout.

This isolated section is a "switched section" that will be dead when the crossover is set to the crossing position, therefore preventing a train derailing or causing a short circuit by crossing point-work that is set against it.

How does it work? Look at the blue wires. We attach one to the main track power and we attach the other to the short isolated section. These two wires are attached to an SPDT on-on switch on the Cobalt point motor.

In the drawing, one wire is connected to the common terminal (c) and the other to the Left (l) terminal.

Note: In reality that 2nd wire MAY need to be connected to the Right (r) terminal. It will depend on the actual orientation of the motor vs the point when you install it.

The Indicator LED. This is an option some modellers may wish to add - Not strictly needed of course, but perhaps it's a good idea for club layouts or those with guest operators who may need a little added help when operating!

Again, it is a really simple addition. Use a red LED and appropriate resistor (I suggest 1k to 5k ohms, depending on the LED choice) OR perhaps a flashing red LED.

Connect one side of the LED to the red track bus directly, & the other as per the Orange dotted lines, to the spare terminal on the same SPDT switch on the cobalt motor. (we connect to both in the drawing. You could connect only to ONE if they are always switched together.

Making it possible for the average modeller to do this sort of thing, easily and without the need for added cost or complexity, was a key concept in the design of Cobalt making it "The point motor that can do it all".

With TWO switches on Cobalt iP Digital and THREE on Cobalt Ω Omega & iP Analog, the options are endless!

Wiring Point-work & Special track conditions for DC or DCC

Adding Safety interlocking: #2 - Automation of point direction change to prevent problems.

This is easy to do with any situation, and is VERY useful for things like hidden yards or layouts where operators may not be totally "on-the-ball". You can use this same automation principal in many layout situations!

This is an easy way to fully automate a point change by adding a detector linked in parallel to the Cobalt switch connections of a Cobalt iP Digital, Cobalt AD-2fx / AD-8fx decoder OR an AD-S2fx / AD-S8fx Solenoid decoder.

This scenario is the same as the last page so frog wiring and "stop automation" would be the same. To keep this approach clear we will show only the ADDED wiring that's associated with automation & switching of Cobalt.

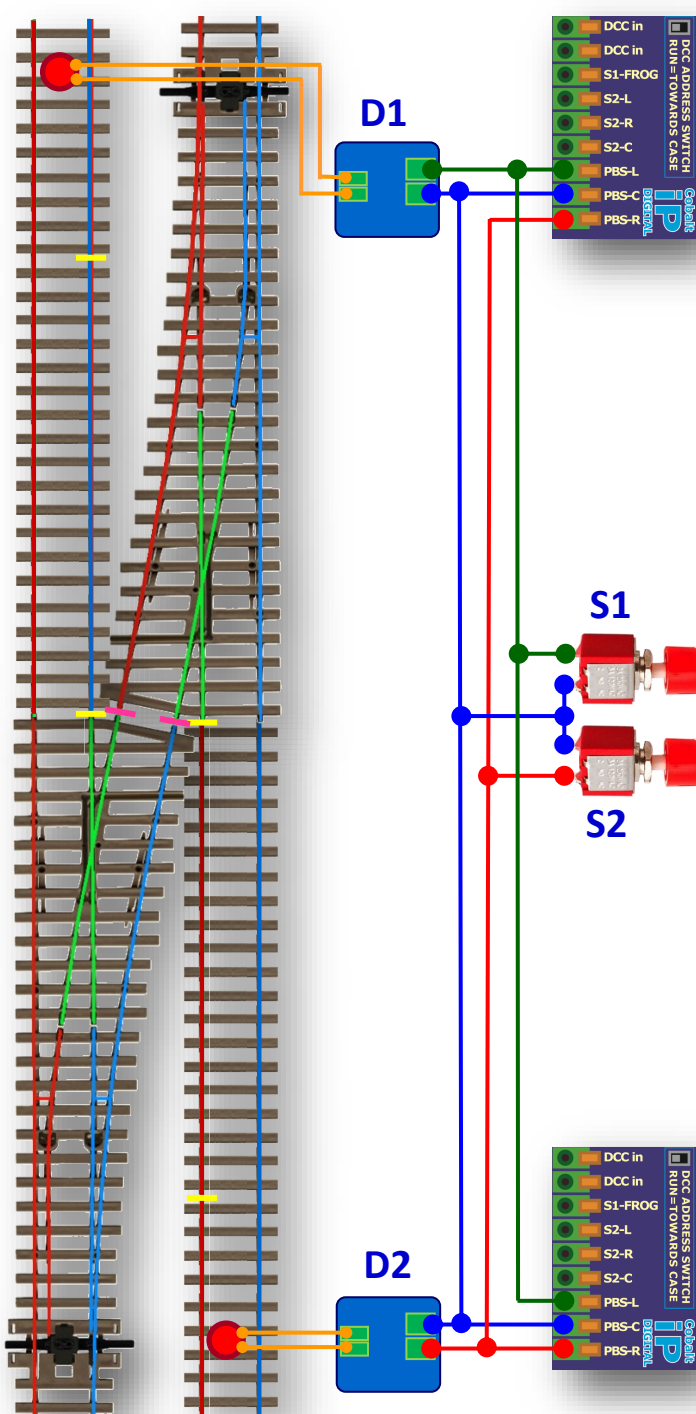

For the purposes of this diagram, this represents an Infra-Red detector. We chose this type because it does not need any "track circuiting" and so it is really easy to add to the layout and wire into your system.

Infra-Red also gives you total choice of positioning. Because of this it is easy to place it exactly where it needs to be to give the points time to change before the train arrives. (or before it reaches the "dead section" detailed on the previous page).

Detailed explanation: We have used a crossover to show how control switching is in parallel (of course, on DC layouts both Cobalt iP digital or decoder would also have the same address)

D1 and D2 are detectors. We chose infra-red but any form of detector you want to use will be OK.

S1 and S2 are momentary Push-Button Switches. These are standard switches as often used on model railways and they do not need to be high power... but they DO need to be 100% reliable so we recommend you use ours.

Digital switch pack # DCP-CMS-D.

As you can see, it includes optional switch caps as well as a variety of chrome mount panel LEDs so it is excellent value!



How it all works: A detector output is in reality an automated kind of switch, and it closes or activates when a sensor that is attached to it is triggered by a passing train. We have therefore wired a detector in parallel with each pushbutton switch.

The Cobalt motor will now act and change the point either when the detector/ Infra-red sensor is triggered, if the switch is pressed, or if you command it with a DCC control system.

We can do this because it's safe to connect the detectors low-voltage output directly to the push-button control terminals on our Cobalt iP Digital motors (or to our AD-2fx/AD-8fx motor drive and our AD-S2fx/AD-S8fx Solenoid Accessory Decoders).

Simple, isn't it!

Note: this may not be OK with other devices or other accessory decoder brands, so before doing it with them, check carefully!

(The output of all detectors while they are NOT activated is usually 0 volts. This switches to a low voltage output (usually 3~5v DC) when the detector has been triggered).

Wiring Point-work & Special track conditions for DC or DCC

Wiring a 3-WAY (and interlocking blade position)

We show an asymmetric 3-way here, however the issue of an "illogical route" exists with a symmetrical 3-way too, so you can use this approach for that too.

Wiring will be exactly the same for DC and DCC modellers.

Also - we've used an AD-2fx decoder however the outputs of a DPDT switch would be wired the same and work the same way.

Cobalt Users: We've shown Cobalt Ω Omega here - Exactly the same wiring can be used with Cobalt iP Analog. For Cobalt iP Digital, you would use the frog switch and then use the second SPST switch to create the power-wiring interlock for motor A.

Solenoid users: This configuration needs two switches per point motor to work, (for frog and power interlock) so Solenoid users will need to use AD-S2fx or AD-S8fx Accessory decoders **plus** the addition of the new DCCconcepts dual relay extension board which is due for release at the end of 2014 / early 2015.

So how does it all work?

Frogs 2 and 3 share the RHS of the straight route and so will always be the same polarity. They're both controlled by motor B.

Frog 1 is only used for the LEFT route controlled by Motor A, so it is controlled by motor A.

Motor A should only be able to set the Left route if Motor B is set to straight. Therefore power feed for Motor A is fed via a switch on Motor B, and is turned OFF by motor B's switch unless motor B is set to straight.

LEDs. If panel LEDs are placed across A's motor power feeds at **X** as per our drawing on page 2, they will **ONLY** be on when motor B is set for the straight Route!

We used an AD-2fx accessory decoder, but the wiring would be just the same if we used a DPDT switch!

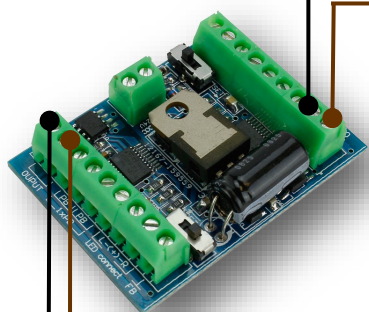

The rest of the AD decoder wiring is as per the AD manual except for the LEDs connected across **X**

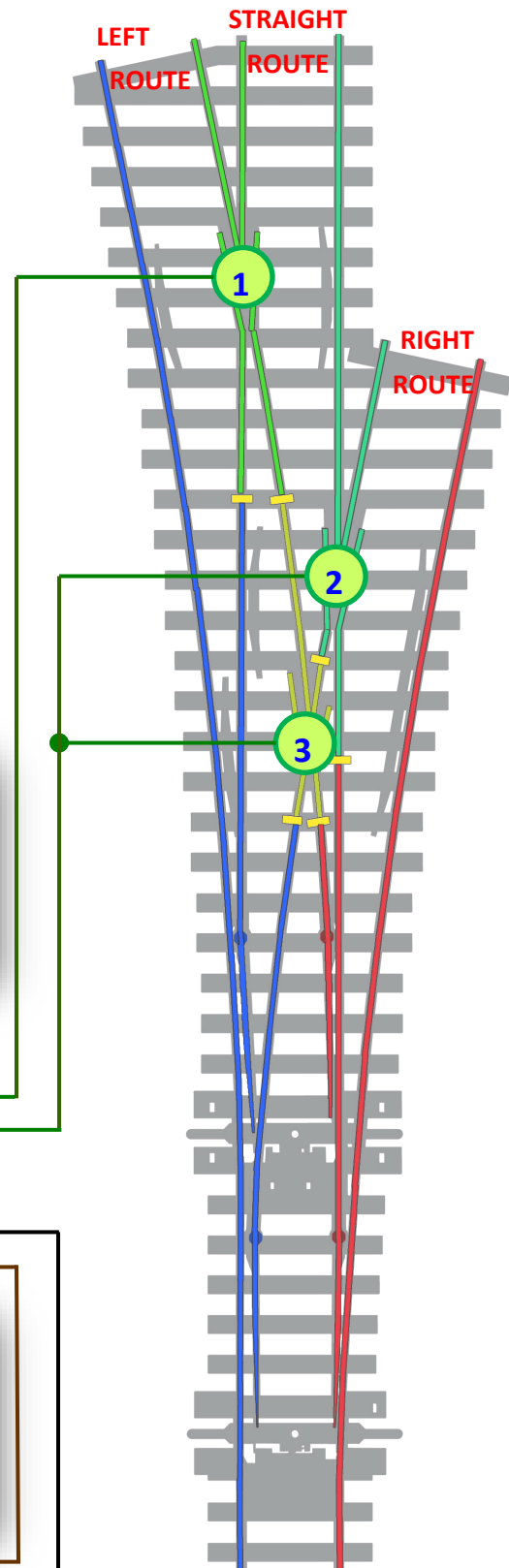
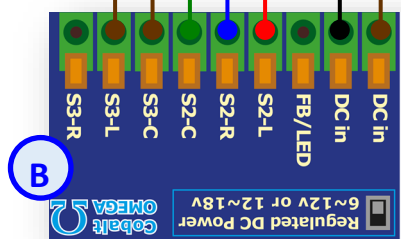
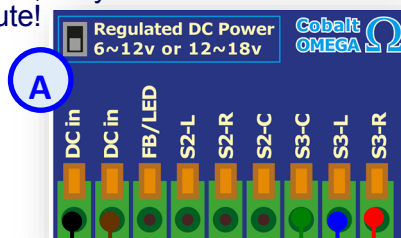

Wiring Point-work & Special track conditions for DC or DCC

Wiring a DOUBLE SLIP for DC/DCC

We have used Cobalt Ω Omega again, however this double-slip could just as easily be wired using solenoids and our AD-S2fx or AD-S8fx solenoid decoder as it has frog switching built-in.

There are only TWO things to remember when you install & wire up a double slip.

- (1) The point motor at one end powers the frog at the other end. (This becomes quite logical if you think of a slip as two points placed on top of each other)
- (2) slips inevitably connect to other kinds of pointwork, and that means lots of isolating gaps at the frogs. Because of this its just easier to always make slips "totally separated electrical sections" when you lay and wire them.

It's all the SAME, DC or DCC

We used an AD-2fx accessory decoder here, and you could use it with DC or DCC as well.

However the wiring would be exactly the same if we used a standard DPDT switch or an SPDT switch and a split-rail power supply.

For Cobalt Ω Omega or Cobalt iP Analog, the LEDs are easy to add using the method that we show on page TWO.

You could also use the AD-2fx LED outputs... but why not save them for signals or similar uses.

Wiring a DIAMOND is just the same as wiring a Double Slip!

Isolate diamonds on all rails, treat them as their own power section.

The difference? The frogs will be controlled by the pointwork that it is connected to. (eg. Installed on the approaches TO the diamond)

Sketch a couple of examples and you will soon see what we mean!

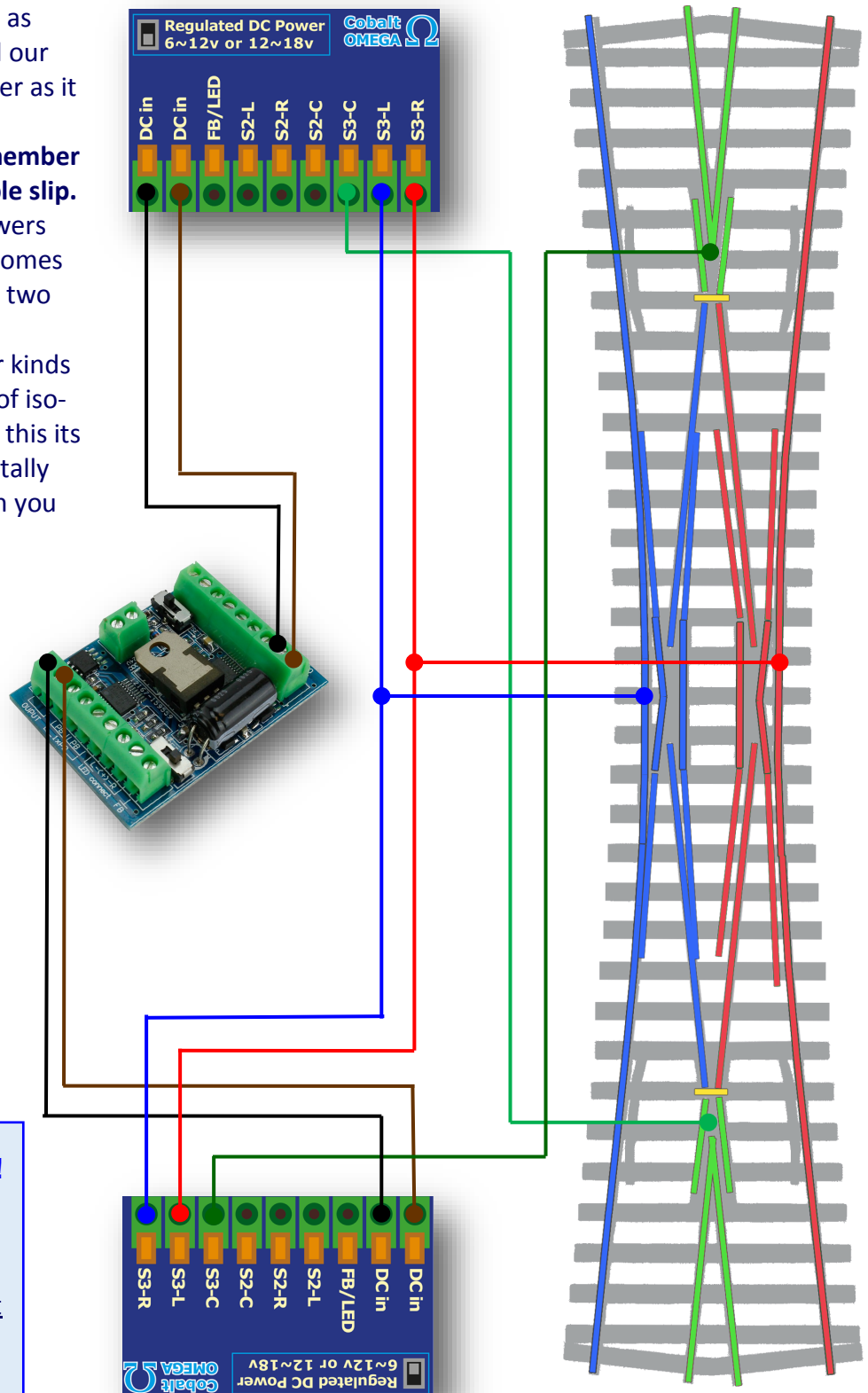

Wiring Point-work & Special track situations for DC or DCC

Wiring a junction that includes DIAMOND Crossings

Many modellers can cope with point-work in general, but their problems start when diamonds are used.

Why? because we think about wiring point-work items individually. In reality, once they are joined, the turnouts & crossings in a formation are all just parts of ONE SET of point-work.

We need to think about them as a whole, rather than singly, to find the best way to wire them.

Here is the thought process: Standard Turnouts are active, but Diamonds are passive things with no moving parts. Even so, their frogs need to be switched. So, frog control must be done via the turnout that leads to the diamond!

Once that's understood, it becomes easy!

How does this example work?

We have shown only the frog wiring to keep it simple. Instructions for Cobalt, AD-2fx and detectors will fill in the gaps...

In this example Cobalt shows one of its very real benefits as it has TWO independent switches for the frogs - That still leaves the FB/LED switch 100% free for signals or panel LEDs. (We used Cobalt Ω Omega but a Cobalt iP Analog would work just as well).

We also added some detectors - 4 in fact!

D1, D2 & D3 are linked so an approach on any main track will set the point to the main position, this also sets the frog polarity so that a train on either main always has a clear path in all respects.

The D4 detector controls the path through the diamond crossing and changes the point and the diamond frogs accordingly.

Control Versatility:

The Cobalt Ω Omega on the turnout is linked via a DCCconcepts AD-2fx. This accessory decoder will work with either DC or DCC power and it will accept direct connection of the detectors to its switch inputs.

This junction can therefore be controlled by DCC, by push-button switches OR by the Infra-red Detectors we have linked to it...

So this solution will work for all, giving you guarded, reliable junction control whether you operate your trains with DC or DCC!

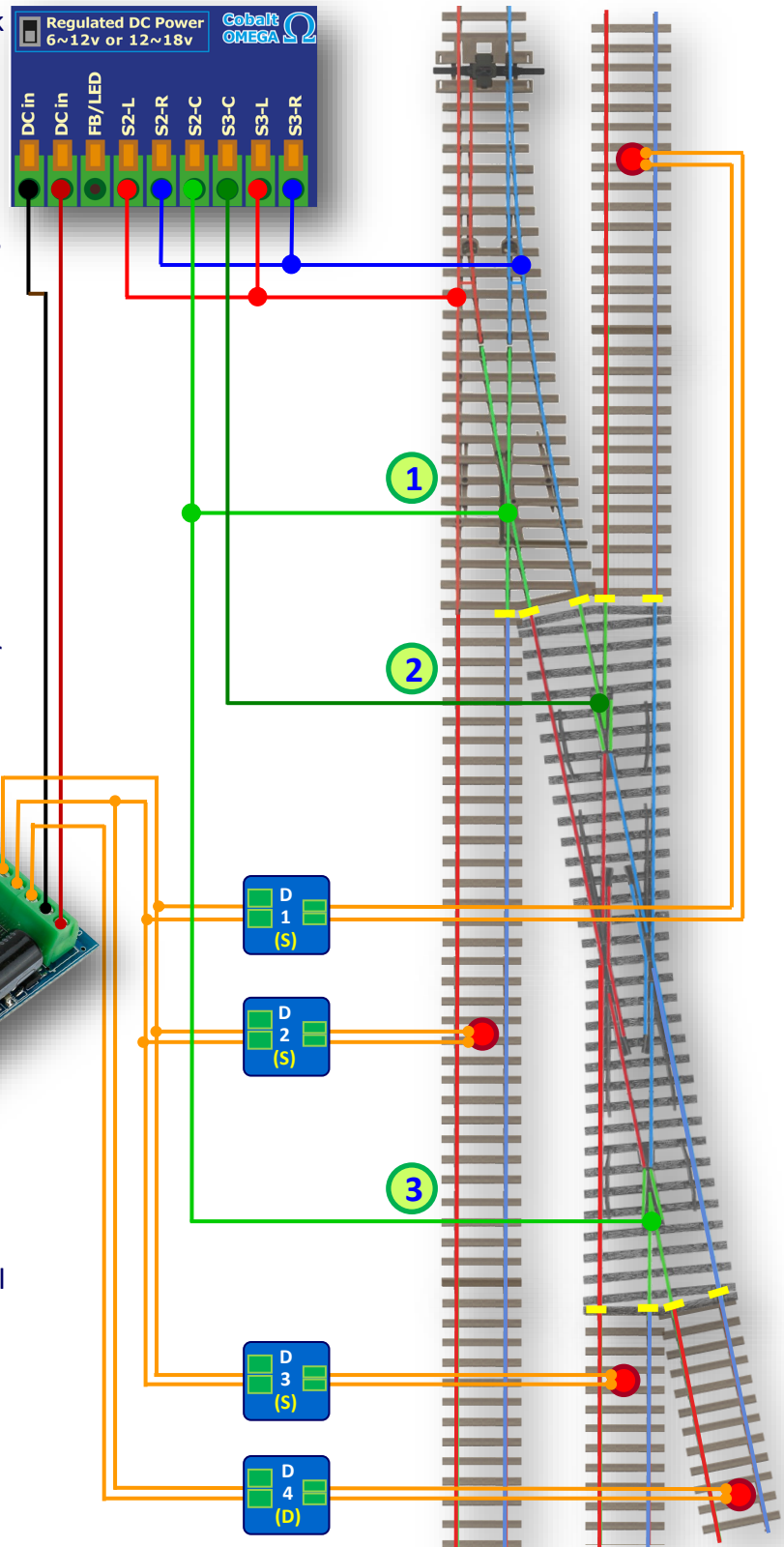

Wiring Point-work & Special track conditions for DC or DCC

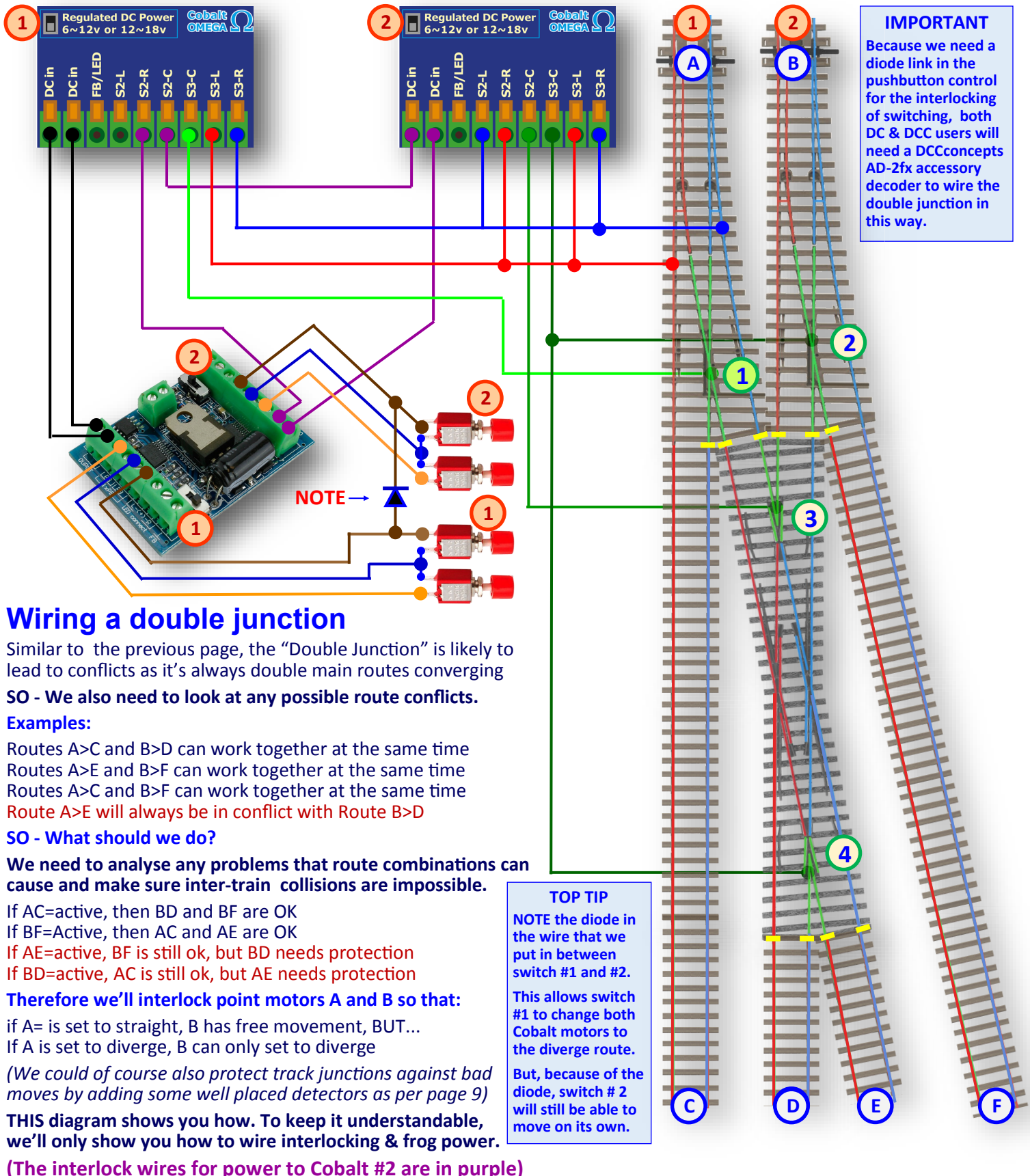

IMPORTANT
Because we need a diode link in the pushbutton control for the interlocking of switching, both DC & DCC users will need a DCCconcepts AD-2fx accessory decoder to wire the double junction in this way.

Wiring a double junction

Similar to the previous page, the "Double Junction" is likely to lead to conflicts as it's always double main routes converging

SO - We also need to look at any possible route conflicts.

Examples:

Routes A>C and B>D can work together at the same time

Routes A>E and B>F can work together at the same time

Routes A>C and B>F can work together at the same time

Route A>E will always be in conflict with Route B>D

SO - What should we do?

We need to analyse any problems that route combinations can cause and make sure inter-train collisions are impossible.

If AC=active, then BD and BF are OK

If BF=Active, then AC and AE are OK

If AE=active, BF is still ok, but BD needs protection

If BD=active, AC is still ok, but AE needs protection

Therefore we'll interlock point motors A and B so that:

if A= is set to straight, B has free movement, BUT...

If A is set to diverge, B can only set to diverge

(We could of course also protect track junctions against bad moves by adding some well placed detectors as per page 9)

THIS diagram shows you how. To keep it understandable, we'll only show you how to wire interlocking & frog power.

(The interlock wires for power to Cobalt #2 are in purple)

TOP TIP

NOTE the diode in the wire that we put in between switch #1 and #2.

This allows switch #1 to change both Cobalt motors to the diverge route.

But, because of the diode, switch # 2 will still be able to move on its own.

Wiring Point-work & Special track conditions for DC or DCC

This is Scissors diagram 1 of 4 INTERLOCKING CROSSOVERS

Wiring a scissors crossing

That means SIX frogs to wire up! ...but don't worry... its not really all that hard to do if you break it down and think it through.

A Scissors is just two crossovers (XO) on top of each other after all.

If we are clever and think it through, we can make it so that only ONE can be set to cross at once, then it becomes easy.

Use Cobalt Ω Omega or Cobalt iP Analog , as they have 3x on-board SPDT switches, so there'll be plenty of capacity to do it all, even leaving you enough switches for the control of LEDs on your control panel!

(Note: Analog motors have 3, Digital has 2)

A scissors looks more intimidating than it needs to be. To keep it simple for you to understand, I will break this wiring up into four totally separate easily understood diagrams.

Interlocking: (Diagram 1) This is the key. It only lets one XO be set at a time.

If we do that, each crossover can control its own frogs & share the diamond frog control. 2x SPDT Switches do the interlocking.

Frog Switching: (Diagram 2)

Using on-board SPDT Switches to do all of the frog switching that's needed. (6 frogs)

Adding a "Safety gap": (Diagram 3)

This leaves us 2x independent SPDT switches. We can use them to prevent trains over-running a crossover that is set against them.

Adding LEDs and Signals: (Diagram 4)

Despite having all of the above, we still have spare "power input linked" switches on the Cobalt Omega, iP Analog & AD-2fx for use with Panel LEDs and signalling. Here's how.

TWO final thoughts on scissors crossings.

(1) Yes, they look neat, but... the prototype used scissors crossings rarely - only when there was no other option, because complex point-work tends to create lots of problems. SO: If you can, use two crossovers instead.

(2) If you MUST use a scissors... be sure the one you choose works with your locos and stock. Wheel profiles and back to backs need to match the track properly and many "Off the shelf" scissors DO give big problems!

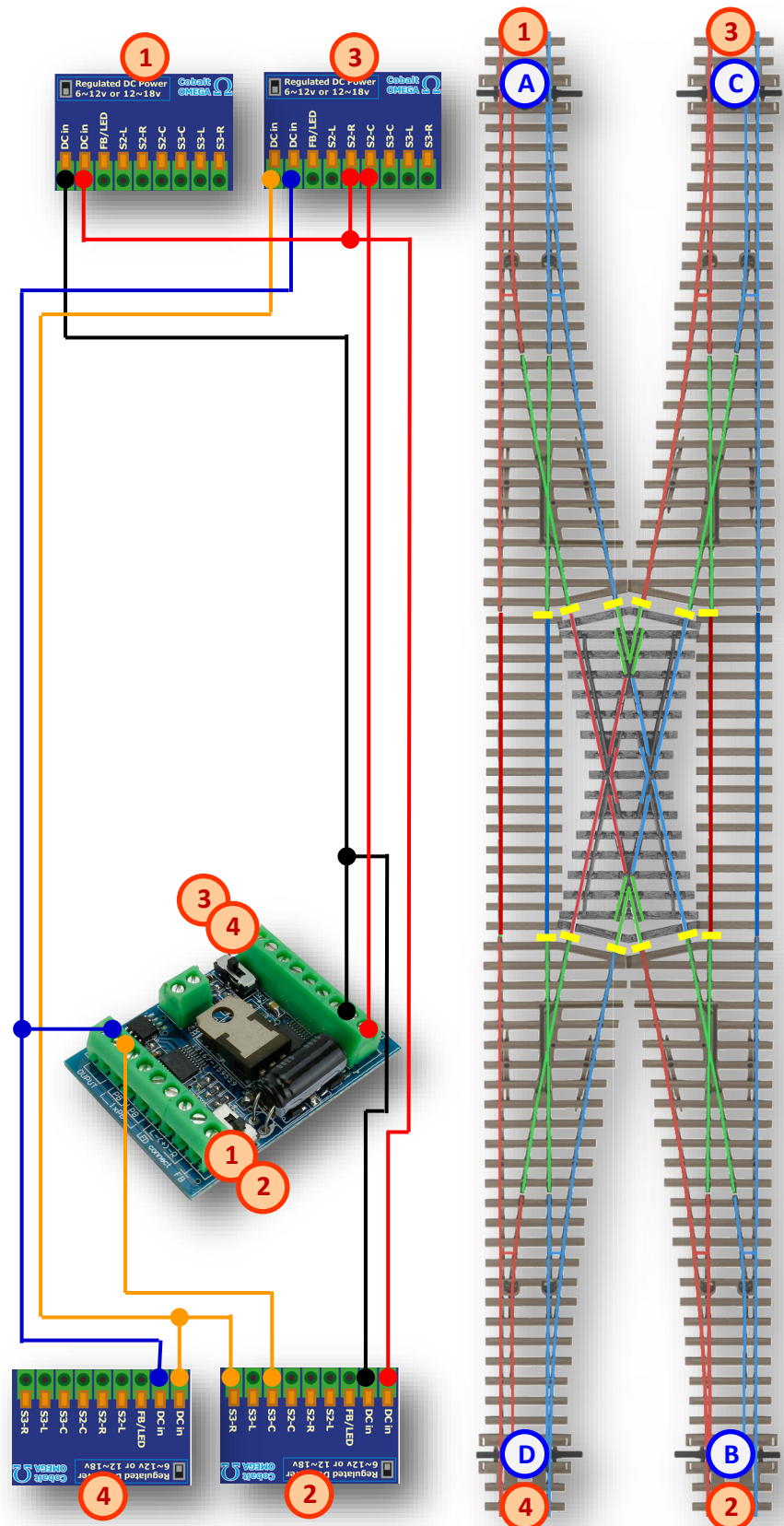

DC or DCC, it's much easier to use Cobalt Analog motors (Omega or iP Analog) plus AD-2fx for scissors wiring

Wiring Point-work & Special track conditions for DC or DCC

**This is Scissors diagram 2 of 4
WIRING the SCISSORS FROGS**

Wiring a scissors crossing

That means SIX frogs to wire up! ...but don't worry... its not really all that hard to do if you break it down and think it through.

A Scissors is just two crossovers (XO) on top of each other after all.

If we are clever and think it through, we can make it so that only ONE can be set to cross at once, then it becomes easy.

Use Cobalt Ω Omega or Cobalt iP Analog , as they have 3x on-board SPDT switches, so there'll be plenty of capacity to do it all, even leaving you enough switches for the control of LEDs on your control panel!

(Note: Analog motors have 3, Digital has 2)

A scissors looks more intimidating than it needs to be. To keep it simple for you to understand, I will break this wiring up into four totally separate easily understood diagrams.

Interlocking: (Diagram 1) This is the key. It only lets one XO be set at a time.

If we do that, each crossover can control its own frogs & share the diamond frog control. 2x SPDT Switches do the interlocking.

Frog Switching: (Diagram 2)

Using on-board SPDT Switches to do all of the frog switching that's needed. (6 frogs)

Adding a "Safety gap": (Diagram 3)

This leaves us 2x independent SPDT switches. We can use them to prevent trains over-running a crossover that is set against them.

Adding LEDs and Signals: (Diagram 4)

Despite having all of the above, we still have spare "power input linked" switches on the Cobalt Omega, iP Analog & AD-2fx for use with Panel LEDs and signalling. Here's how.

TWO final thoughts on scissors crossings.

(1) Yes, they look neat, but... the prototype used scissors crossings rarely - only when there was no other option, because complex point-work tends to create lots of problems. SO: If you can, use two crossings instead.

(2) If you MUST use a scissors... be sure the one you choose works with your locos and stock. Wheel profiles and back to backs need to match the track properly and many "Off the shelf" scissors DO give big problems!

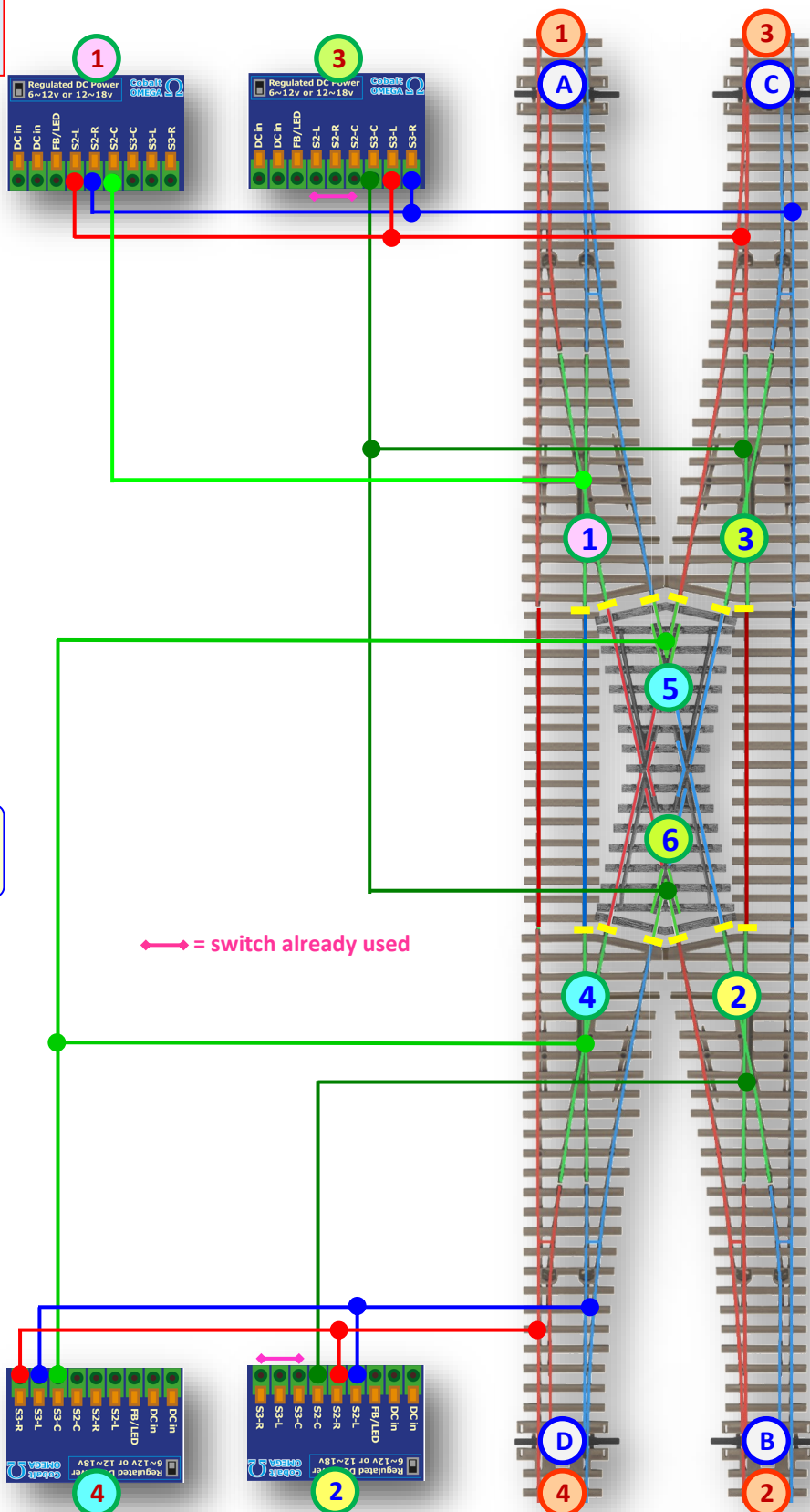

DC or DCC, it's much easier to use Cobalt Analog motors (Omega or iP Analog) plus AD-2fx for scissors wiring

Wiring Point-work & Special track conditions for DC or DCC

This is Scissors diagram 3 of 4
ADDING SAFETY INTERLOCKS

Wiring a scissors crossing

That means SIX frogs to wire up! ...but don't worry... its not really all that hard to do if you break it down and think it through.

A Scissors is just two crossovers (XO) on top of each other after all.

If we are clever and think it through, we can make it so that only ONE can be set to cross at once, then it becomes easy.

Use Cobalt Ω Omega or Cobalt iP Analog , as they have 3x on-board SPDT switches, so there'll be plenty of capacity to do it all, even leaving you enough switches for the control of LEDs on your control panel!

(Note: Analog motors have 3, Digital has 2)

A scissors looks more intimidating than it needs to be. To keep it simple for you to understand, I will break this wiring up into four totally separate easily understood diagrams.

Interlocking: (Diagram 1) This is the key. It only lets one XO be set at a time.

If we do that, each crossover can control its own frogs & share the diamond frog control. 2x SPDT Switches do the interlocking.

Frog Switching: (Diagram 2)

Using on-board SPDT Switches to do all of the frog switching that's needed. (6 frogs)

Adding a "Safety gap": (Diagram 3)

This leaves us 2 independent SPDT switches. We can use them to prevent trains over-running a crossover that is set against them.

Adding LEDs and Signals: (Diagram 4)

Despite having all of the above, we still have spare "power input linked" switches on the Cobalt Omega, iP Analog & AD-2fx for use with Panel LEDs and signalling. Here's how.

TWO final thoughts on scissors crossings.

(1) Yes, they look neat, but... the prototype used scissors crossings rarely - only when there was no other option, because complex point-work tends to create lots of problems. SO: If you can, use two crossovers instead.

(2) If you MUST use a scissors... be sure the one you choose works with your locos and stock. Wheel profiles and back to backs need to match the track properly and many "Off the shelf" scissors DO give big problems!

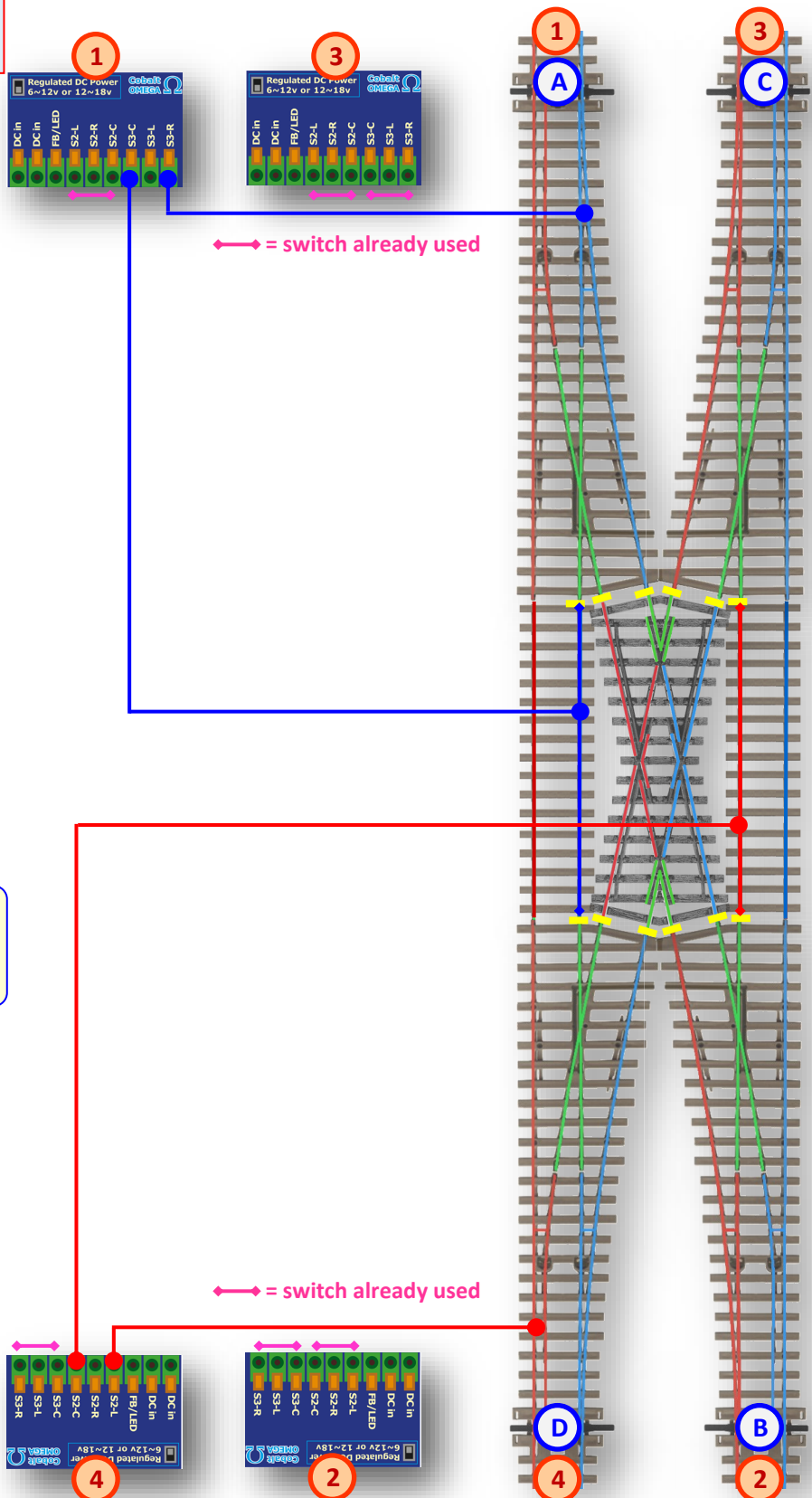

DC or DCC, it's much easier to use Cobalt Analog motors (Omega or iP Analog) plus AD-2fx for scissors wiring

Wiring Point-work & Special track conditions for DC or DCC

This is Scissors diagram 4 of 4
ADDING SAFETY INTERLOCKS

Wiring a scissors crossing

That means SIX frogs to wire up! ...but don't worry... its not really all that hard to do if you break it down and think it through.

A Scissors is just two crossovers (XO) on top of each other after all.

If we are clever and think it through, we can make it so that only ONE can be set to cross at once, then it becomes easy.

Use Cobalt Ω Omega or Cobalt iP Analog , as they have 3x on-board SPDT switches, so there'll be plenty of capacity to do it all, even leaving you enough switches for the control of LEDs on your control panel!

(Note: Analog motors have 3, Digital has 2)

A scissors looks more intimidating than it needs to be. To keep it simple for you to understand, I will break this wiring up into four totally separate easily understood diagrams.

Interlocking: (Diagram 1) This is the key. It only lets one XO be set at a time.

If we do that, each crossover can control its own frogs & share the diamond frog control. 2x SPDT Switches do the interlocking.

Frog Switching: (Diagram 2)

Using on-board SPDT Switches to do all of the frog switching that's needed. (6 frogs)

Adding a "Safety gap": (Diagram 3)

This leaves us 2x independent SPDT switches. We can use them to prevent trains over-running a crossover that is set against them.

Adding LEDs and Signals: (Diagram 4)

Despite having all of the above, we still have spare "power input linked" switches on the Cobalt Omega, iP Analog & AD-2fx for use with Panel LEDs and signalling. Here's how.

TWO final thoughts on scissors crossings.

(1) Yes, they look neat, but... the prototype used scissors crossings rarely - only when there was no other option, because complex point-work tends to create lots of problems. SO: If you can, use two crossovers instead.

(2) If you MUST use a scissors... be sure the one you choose works with your locos and stock. Wheel profiles and back to backs need to match the track properly and many "Off the shelf" scissors DO give big problems!

There are various ways to add Panel lights or colour light signal control.

You could put LEDs across the frog switching... or you can use either of these two easy-to-wire methods.

(We show only ONE set of LEDs wired to AD-2fx to keep the drawing simple)

You can do it this way...
(Use AD-2fx LED outputs)

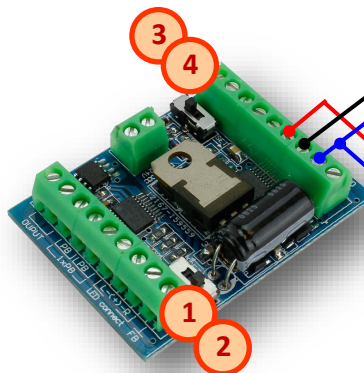

Or you can do it this way
(Across the Cobalt motor power and control inputs)

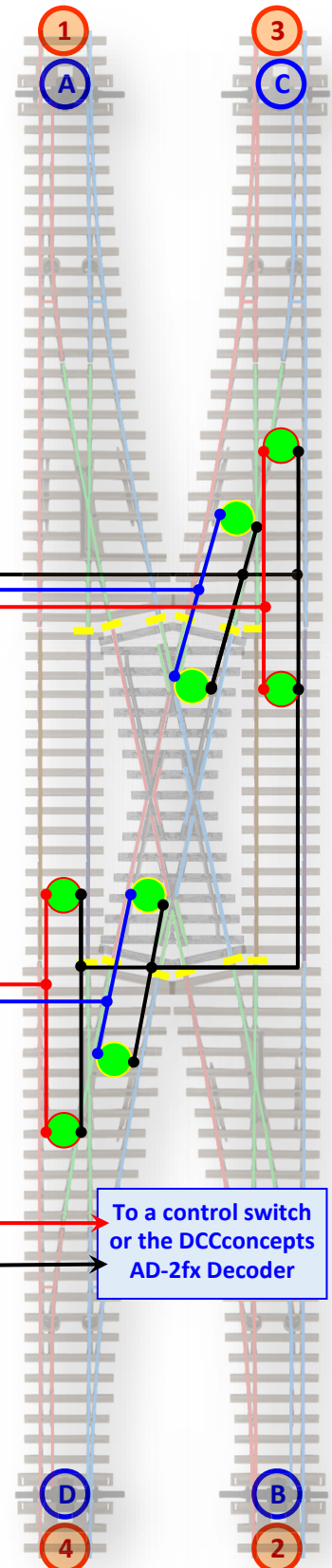
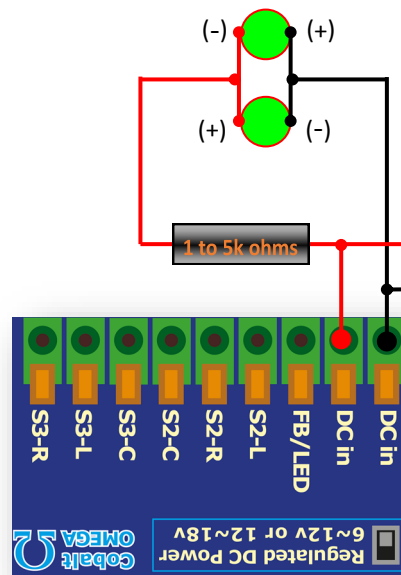

DC or DCC, it's much easier to use Cobalt Analog motors (Omega or iP Analog) plus AD-2fx for scissors wiring

Wiring Point-work & Special track conditions for DC or DCC

Wiring a Reversing loop

A reversing loop is ANY track configuration that allows a train or locomotive to change direction 180 degrees and return on the same track in the opposite direction. It can include teardrop loops, diagonals across ovals, wyes, a terminus entry wye or things like turntables that turn a loco. Here are some examples

(Original track plans are from "Free track plans for your model railway" - To visit them, go to www.freetrackplans.com.

(Reverse loops are in Blue & Purple shades. Red lines indicate the need for both rails to be gapped)

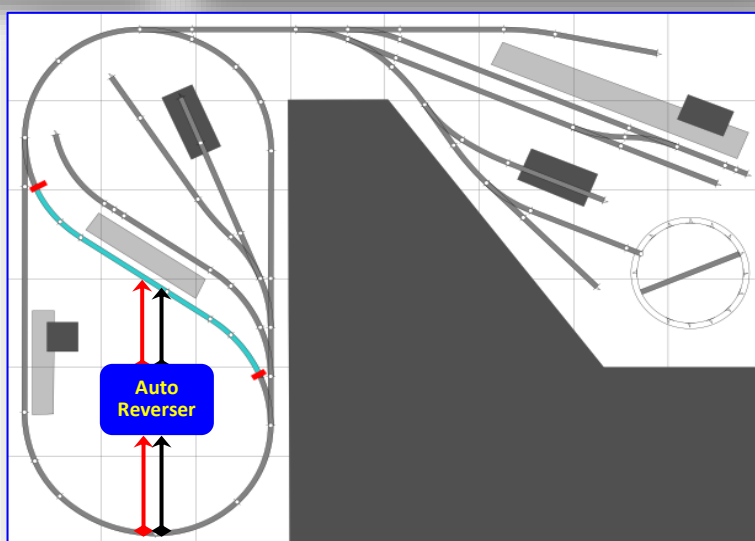
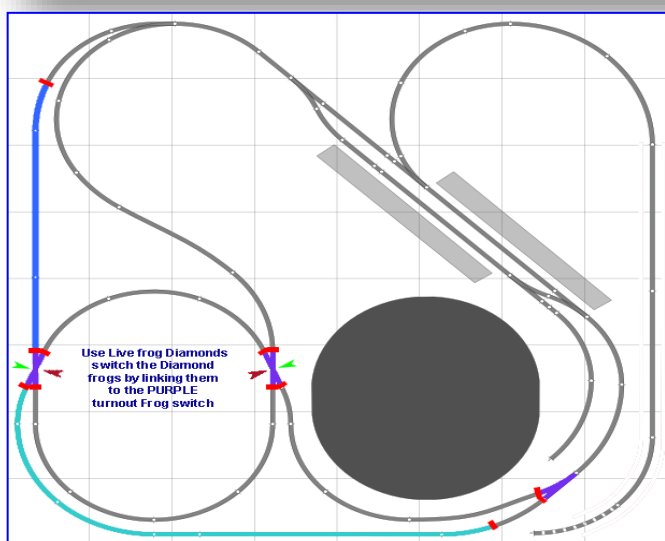
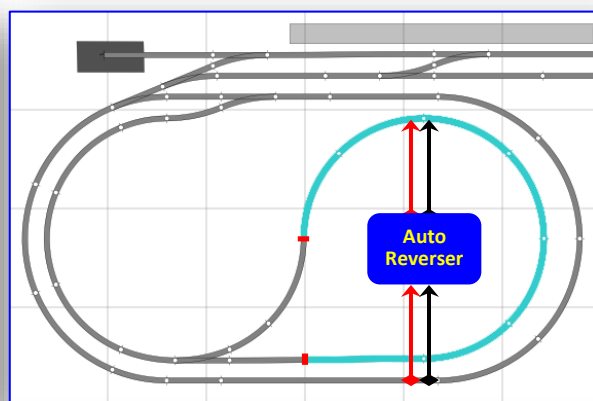
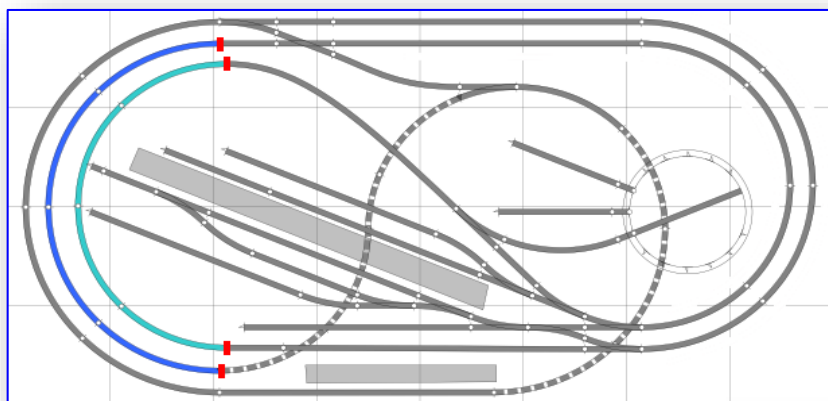

Main principals of wiring any reversing loop or configuration

- (1) BOTH rails must be gapped at both ends of the reversing section. It is advisable to stagger gaps slightly if possible.
- (2) Try to make the reversing section longer than the longest train that will pass through it. This prevents metal wheels and powered rolling stock (such as lit coaches) trying to trigger the loop at the other end while the train is still passing through the section.
- (3) Think about traffic flow. Try to place them so that only ONE train passes a Reverse loop boundary at one time (if two trains try to use a reverse-loop wired area at one time, then there will be potential problems)
- (4) You CAN share an Auto reverser unit between TWO reversing sections IF only one will contain a train at any one time (this can be useful on "track puzzle" type narrow gauge railways with track that loops and twists but very few trains run at any one time.
- (5) In busy areas like station throats, keep the Auto reverse situation as simple as possible to prevent conflict.

Wiring Point-work & Special track conditions for DC or DCC

TURNTABLES...

Most currently available turntables already have a method for coping with polarity reversal, however earlier ready-to-run turntables and most kit-type turntables do not. This leads to annoying sound resets or shorts when they are used.

To fix this, you CAN add a DPDT switch wired as a reversing switch to the bridge tracks, however if you do not want to be bothered changing a switch every time you turn a loco... Just supply the turntable bridge track via an auto-reverser unit.

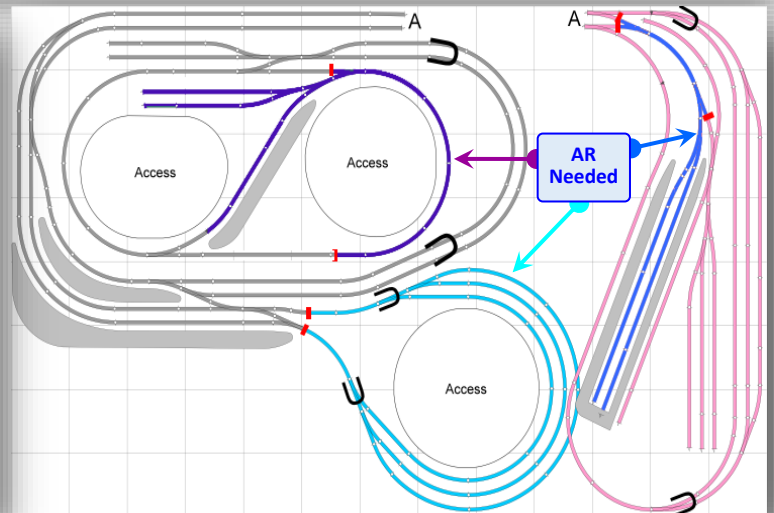
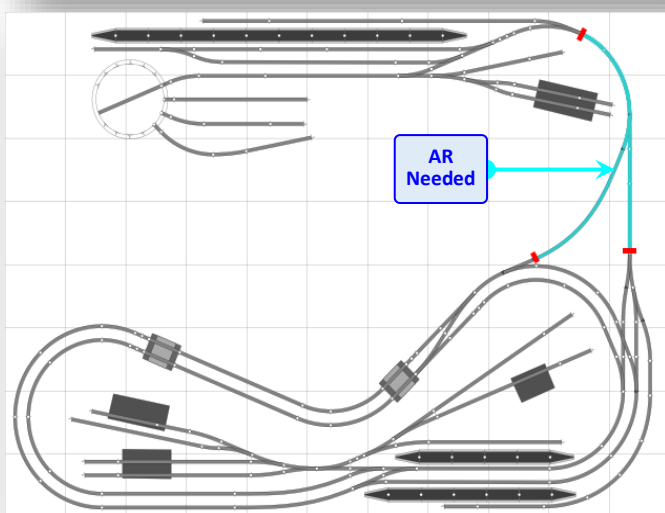
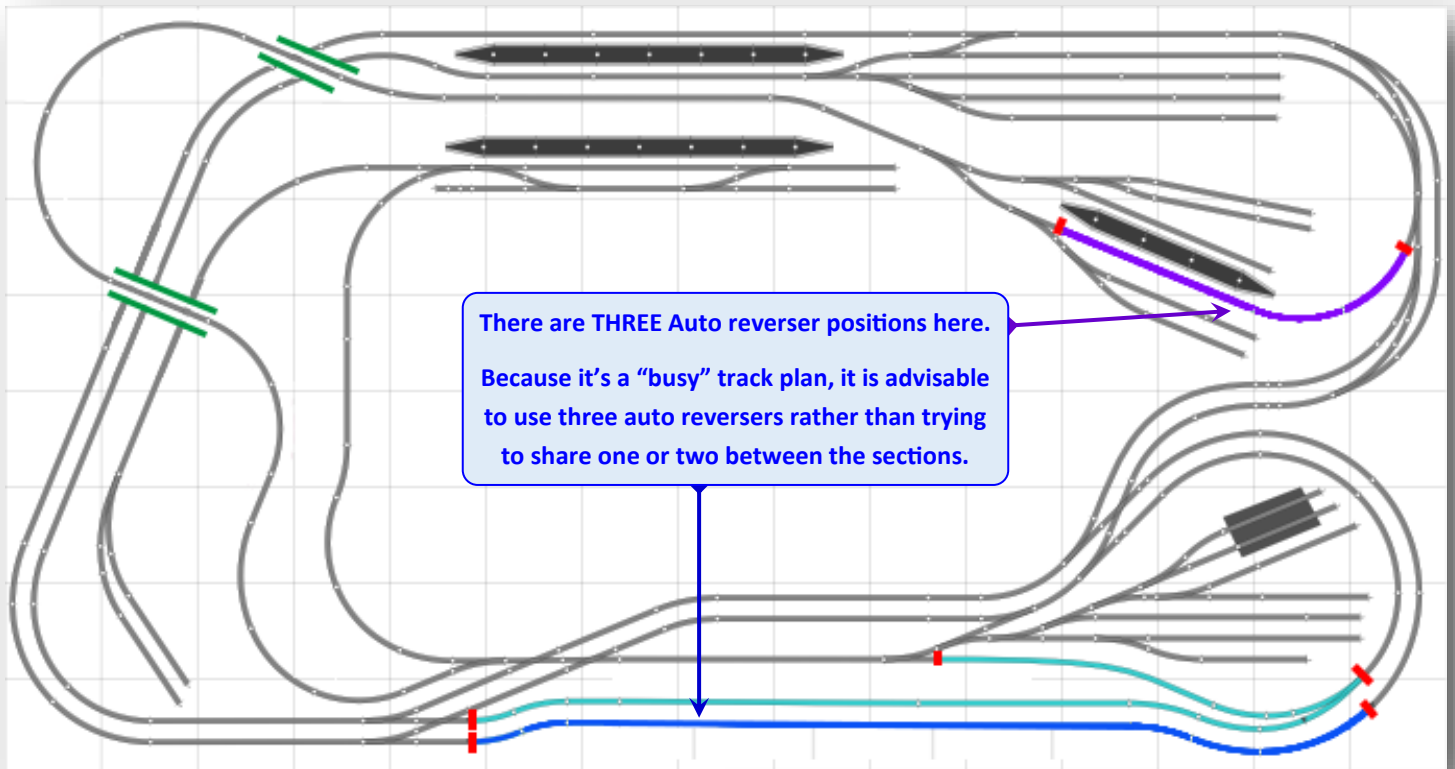

That's it for this Advice section... We hope you've found something interesting or discovered something new in its pages!
If you still have questions, we are happy to help. Email us and ask at questions@dccconcepts.com